

Towards the Partitioning Problem in Software-Defined IoT Networks for Urban Sensing

Chao Song, Jie Wu, Xu Chen, Lei Shi, and Ming Liu

University of Electronic Science and Technology of China, P. R. China

Temple University, USA

IEEE PerCom 2018, Athens Greece

March 22, 2018



电子科技大学
University of Electronic Science and Technology of China



Outlines

Introduction to SD-IoT Network

Partitioning Problem of Large-scale SD-IoT

Solution: PASIN

Evaluation Results

Conclusion

Introduction to SD-IoT Network

Partitioning Problem of Large-scale SD-IoT

Solution: PASIN

Evaluation Results

Conclusion

Internet of Things

- As the Internet of Things (IoT) is fundamental to realizing urban sensing, it should be flexible enough to support various application requirements and the convenient management of infrastructure.

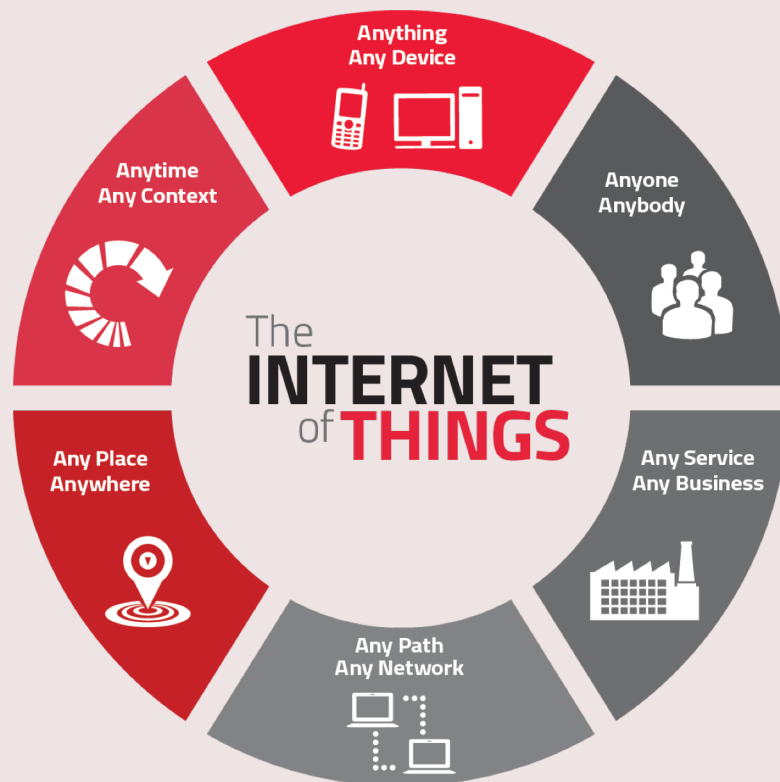

Software-Defined Network

- SDN separates the network into a control plane with a collection of network-attached servers and a data plane with programmable and packet-flow switches.

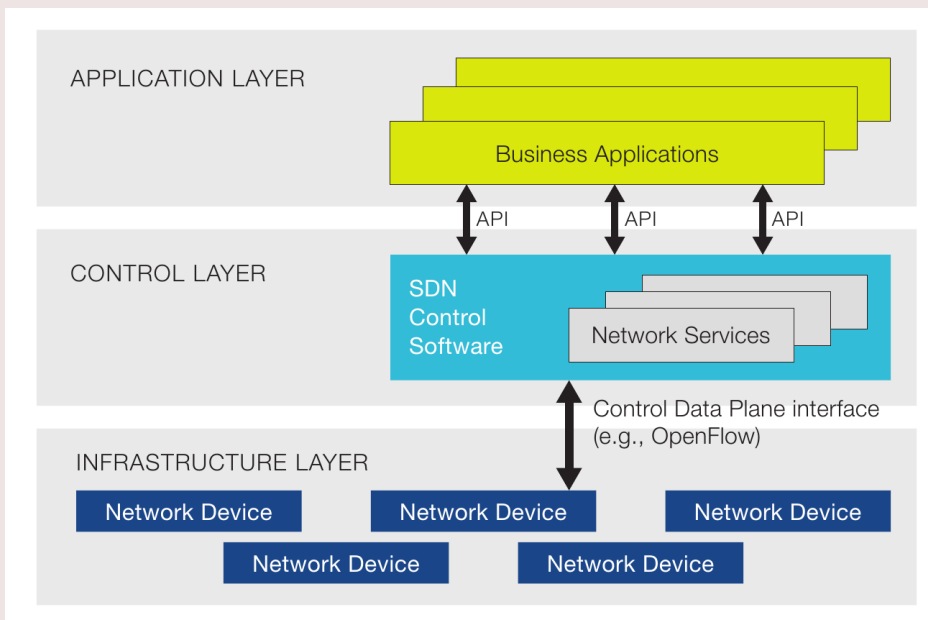

Software-Defined IoT (SD-IoT) Network

- A Software-Defined IoT (SD-IoT) network has been proposed for smart urban sensing.

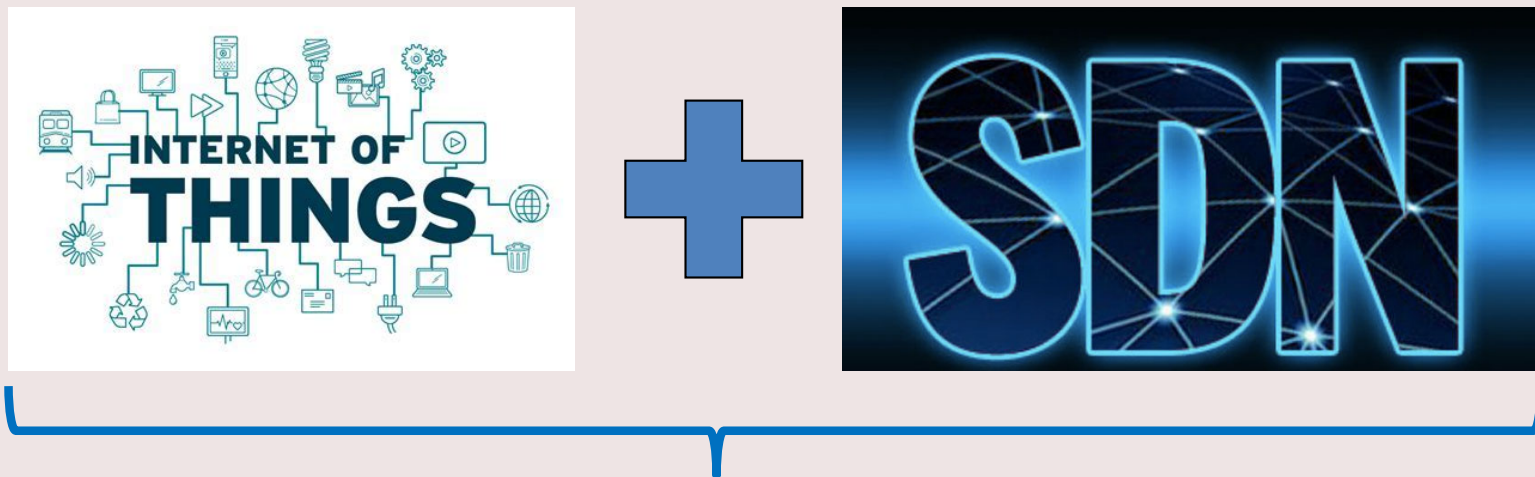

SD-IoT Network

The framework of a SD-IoT system

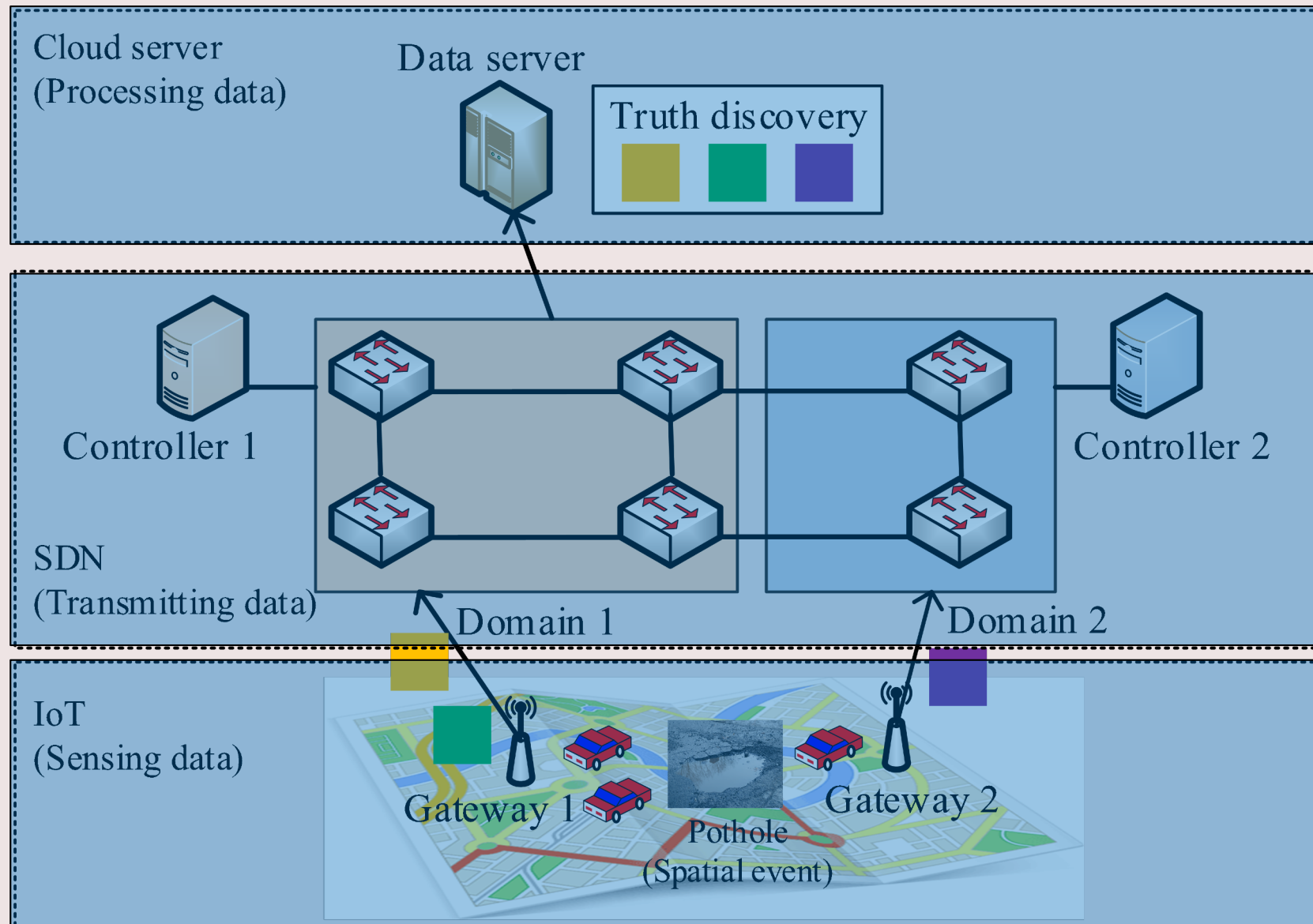

Introduction to SD-IoT Network

Partitioning Problem of Large-scale SD-IoT

Solution: PASIN

Evaluation Results

Conclusion

One intra-domain path (single controller)

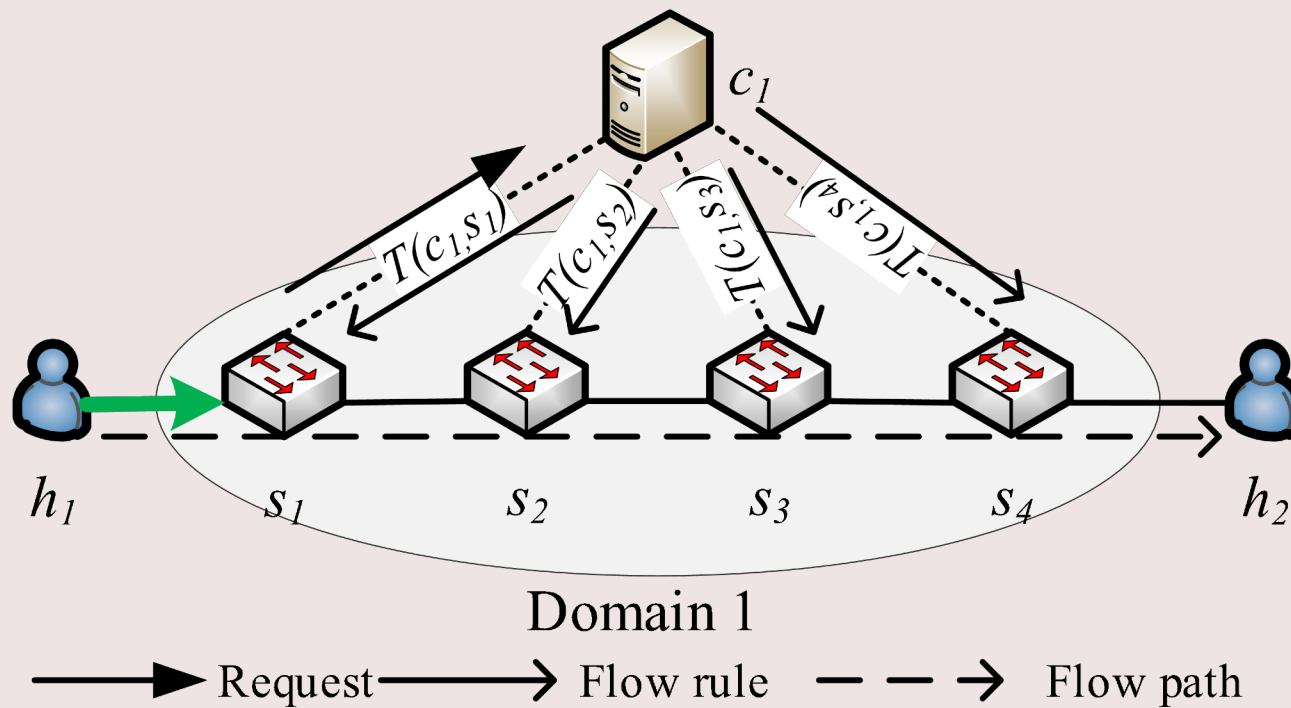

The responses from a controller by CBench

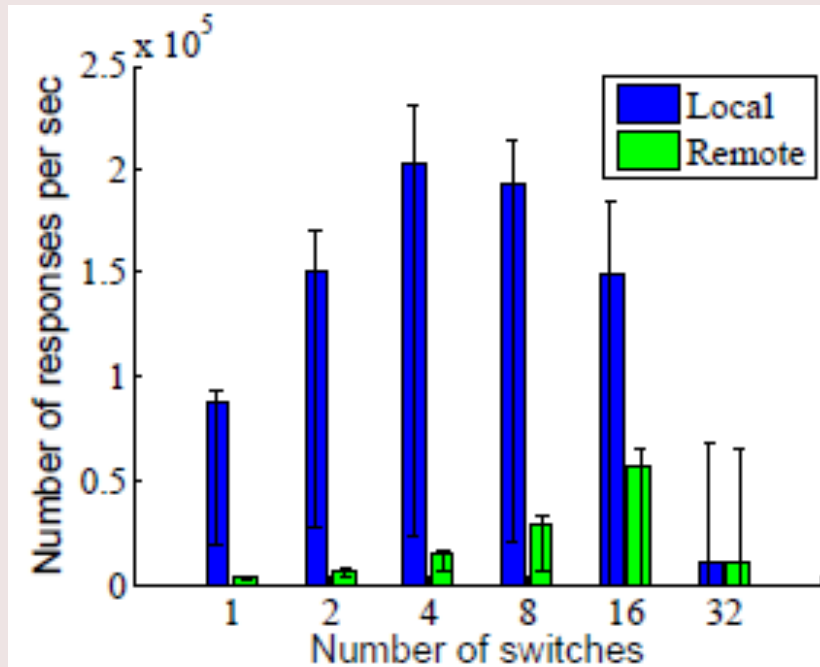

(a) Total responses of all switches

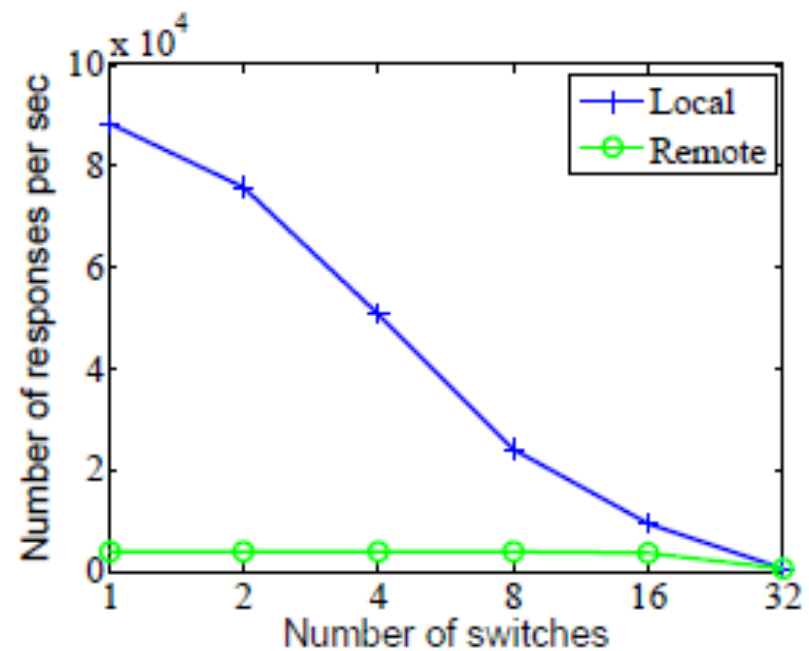

(b) Average responses per switch

Two intra-domain paths (double controllers)

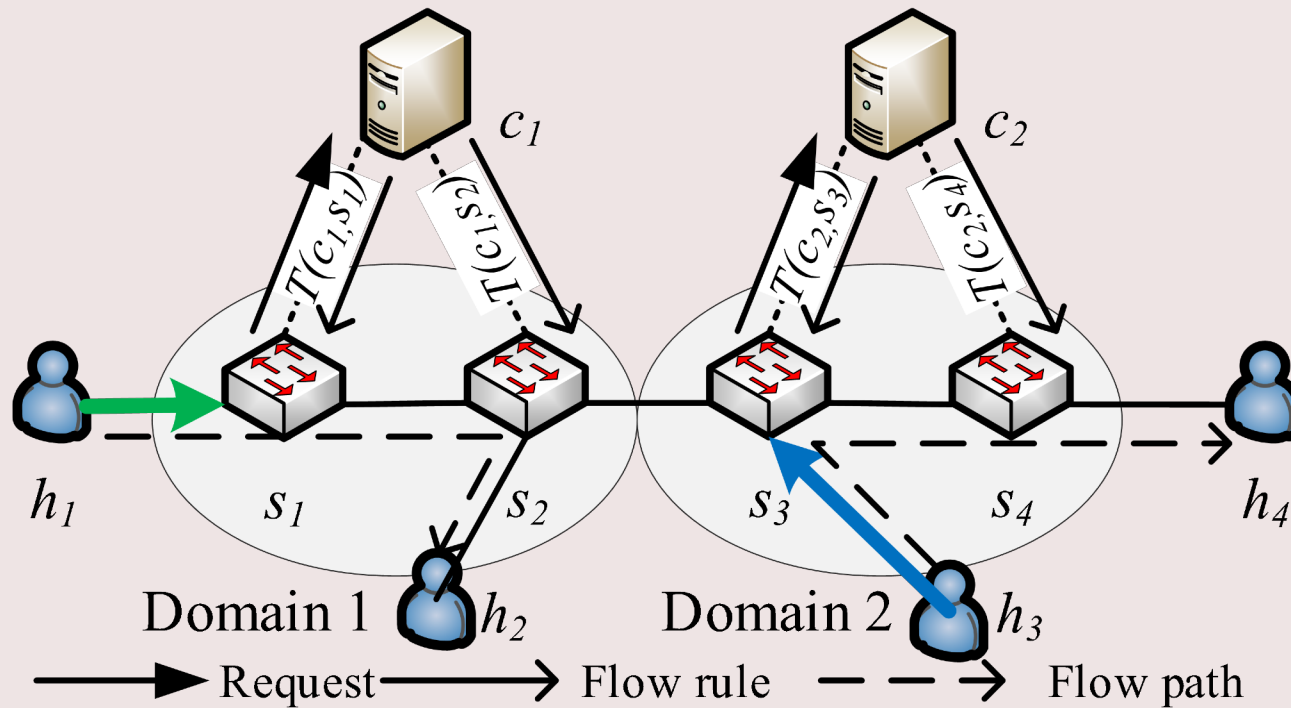

Global Mobile Data Traffic

- Global mobile data traffic grew 63 percent in 2016.
- Almost half a billion (429 million) mobile devices and connections were added in 2016.
- Global mobile data traffic will increase sevenfold between 2016 and 2021.



Global Mobile Devices (Excluding M2M) by 2G, 3G, and 4G+

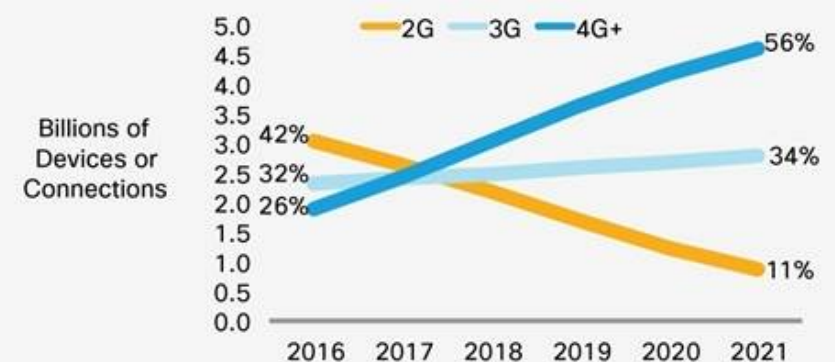

Global Mobile M2M Connections by 2G, 3G, and 4G+

Case of Large-scale IoT: Mobike



IoT device in MoBike



MoBike neaby

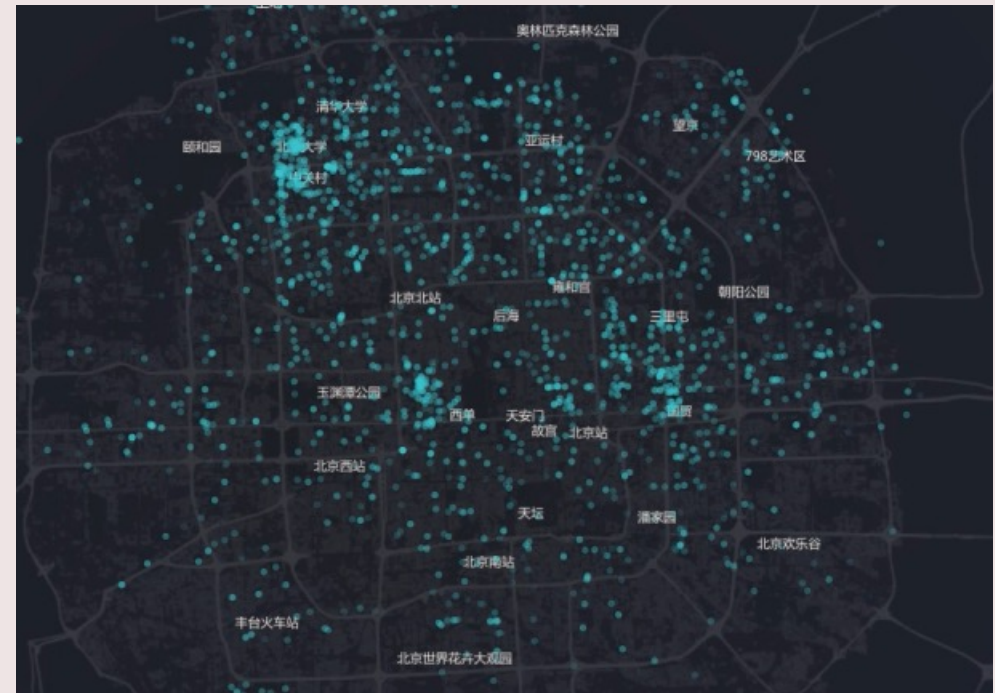

A snapshot of MoBike in the city of Beijing

Partitioning for SD-IoT Network



One inter-domain path (double controllers)

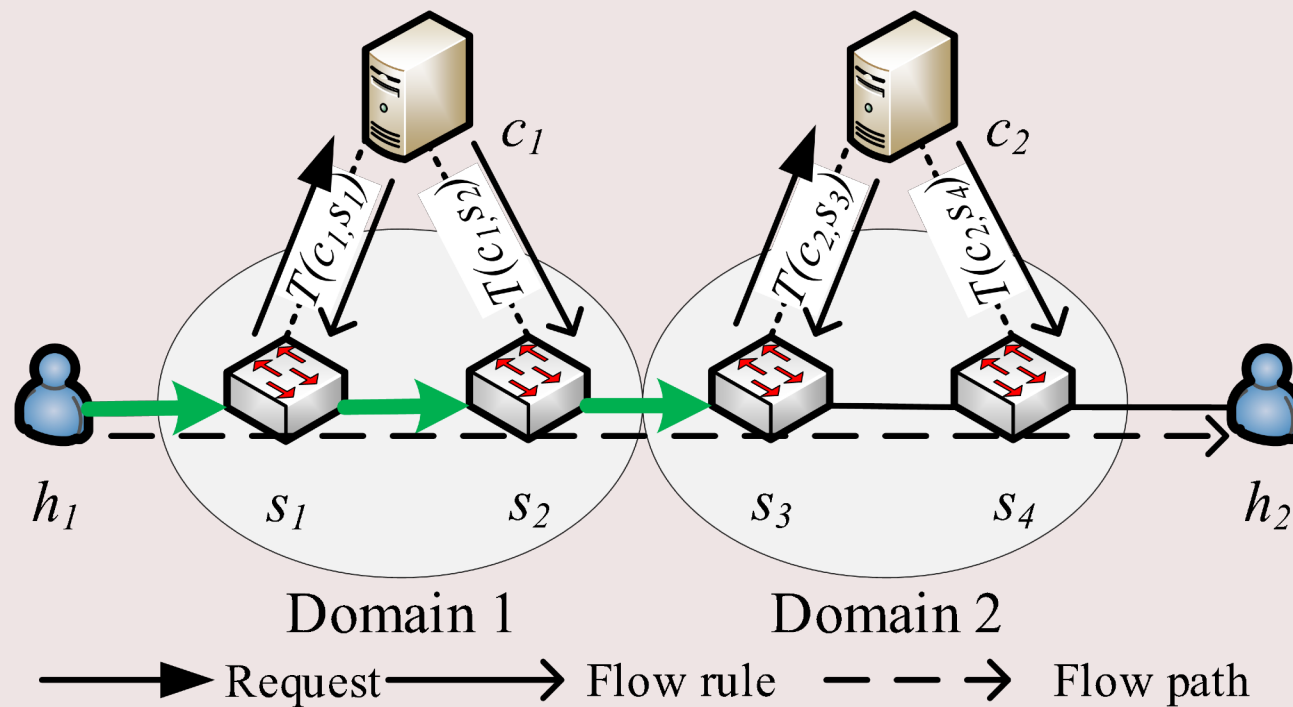

Partitioning Problem of SD-IoT

- We investigate the problem of partitioning SDN with multiple controllers to minimize the total load of requests, which considers the following factors:
 - The request-processing capability of a controller (denoted by L_{max});
 - Load balance among the multiple controllers;
 - The extra loads caused by the inter-domain flow paths;
 - The total switch-to-controller delay.
- Among these factors, the flow paths in SDN are the essential part, which are generated by uploading the sensing data from the gateways to the data servers.

Introduction to SD-IoT Network

Partitioning Problem of Large-scale SD-IoT

Solution: PASIN

Evaluation Results

Conclusion

Traffic Pattern

- Definition (*Traffic Pattern*): each event o_i has a traffic pattern denoted by p_i , which is the set of the gateways upload the sensing reports from event o_i .

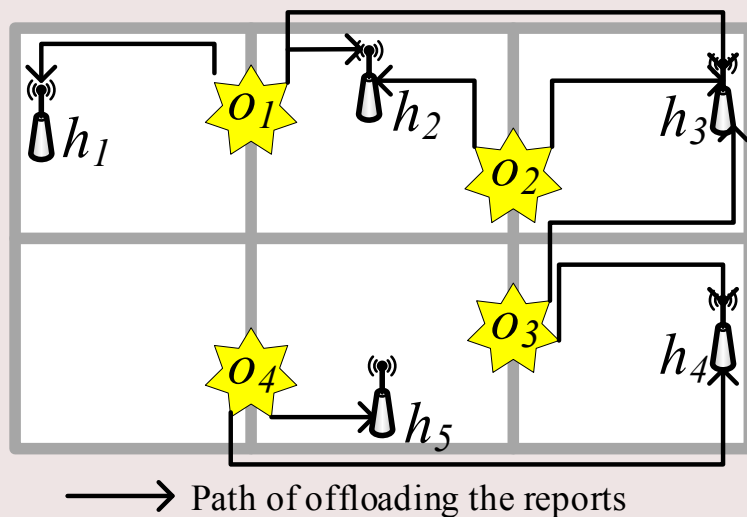

Once a spatial event occurs, a large amount of data flow will arrive at the relative gateways.

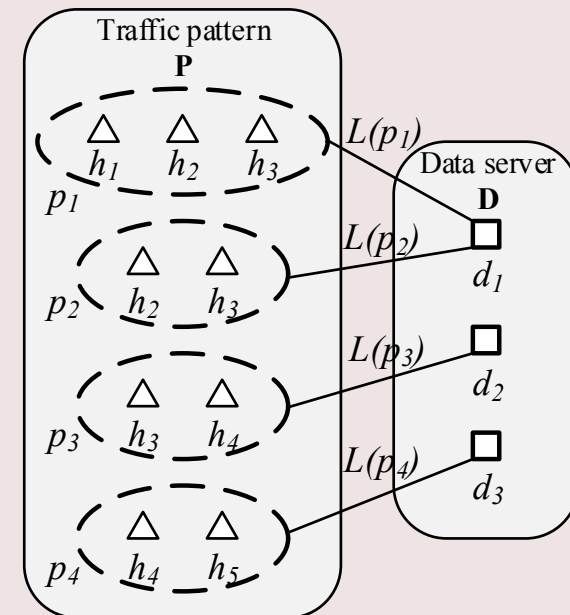

A bipartite graph illustrates the relationship between the traffic patterns and the data servers.

Hypergraph

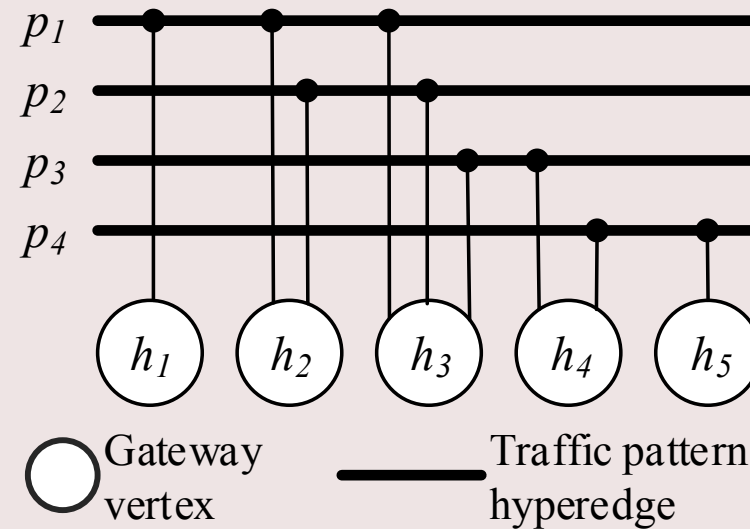

- A bus representation of a hypergraph $H(X, Y)$
- $X = \{h \mid h \in \mathbf{H}\}$: the vertex set X contains all the gateways.
- $Y = \{p \mid p \in \mathbf{P}\}$: Each traffic pattern hyperedge involves multiple gateways, which is the main reason to introduce a hypergraph.
- $M : h \rightarrow c$: the gateway-to-controller mapping function specifies the controller c according to each gateway h .

PASIN: Partitioning Algorithm for Software-defined IoT Network

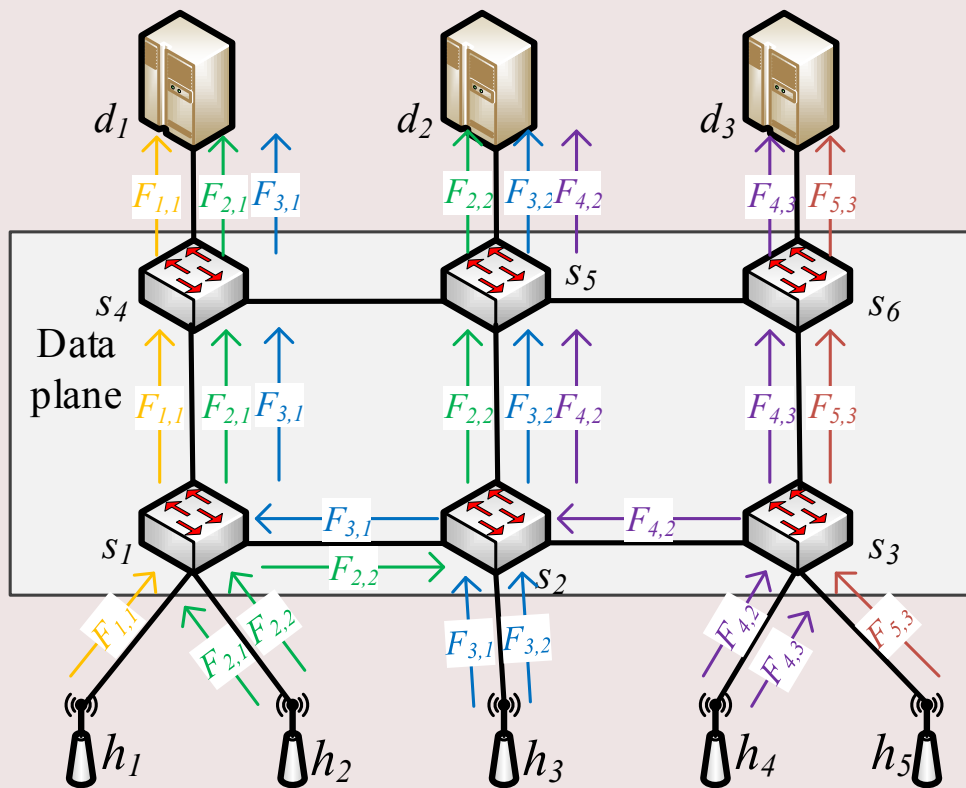

- The flow paths among the switches in SDN.
- Let $F_{i,j}$ denote the flow path from the gateway h_i to the data server d_j .
- The number of requests from the path is denoted by $L(F_{i,j})$.
- A flow path F is an alternating sequence of switches and links, and $F^{(i)}$ represents the i^{th} switch in it.

Graph and Loads

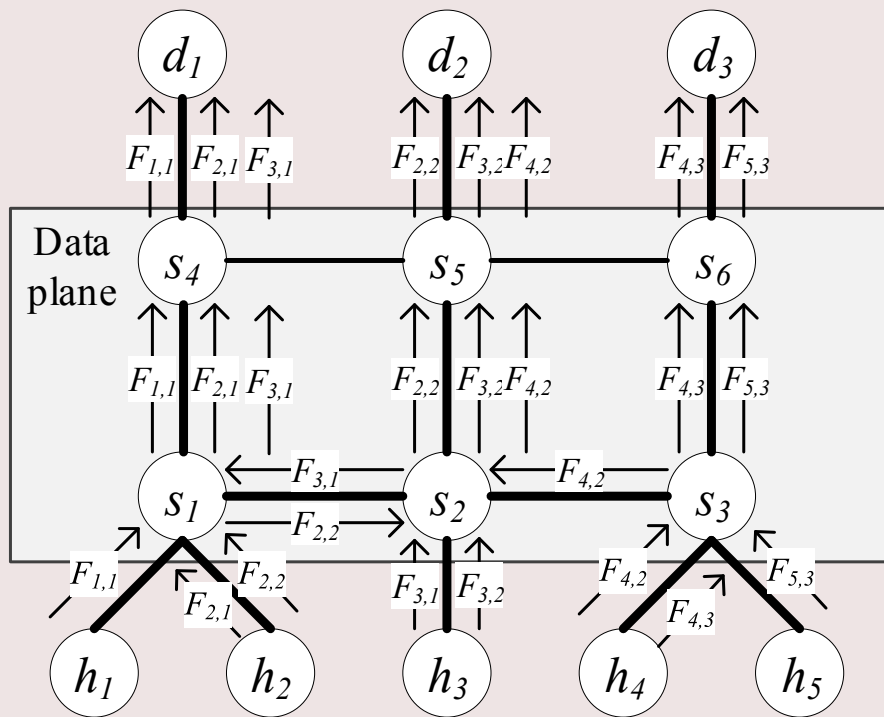

- A graph $G(V,E)$ for data plane
- Load of edge:

$$L(e) = \sum_{F_{i,j} \in \mathcal{F}} L(F_{i,j}) \mathbf{1}(e \in F_{i,j})$$

- Load of vertex:

$$L(s) = \sum_{F_{i,j} \in \mathcal{F}} L(F_{i,j}) \mathbf{1}(s \in F_{i,j})$$

- Difference in transmission delay:

$$\Delta T(s_i, c_j, c_0) = T(s_i, c_j) - T(s_i, c_0)$$

$$\Delta n(s_i, c_j) = \frac{\Delta T(s_i, c_j, c_0)}{q} \cdot L(s_i)$$

Cutting Cost

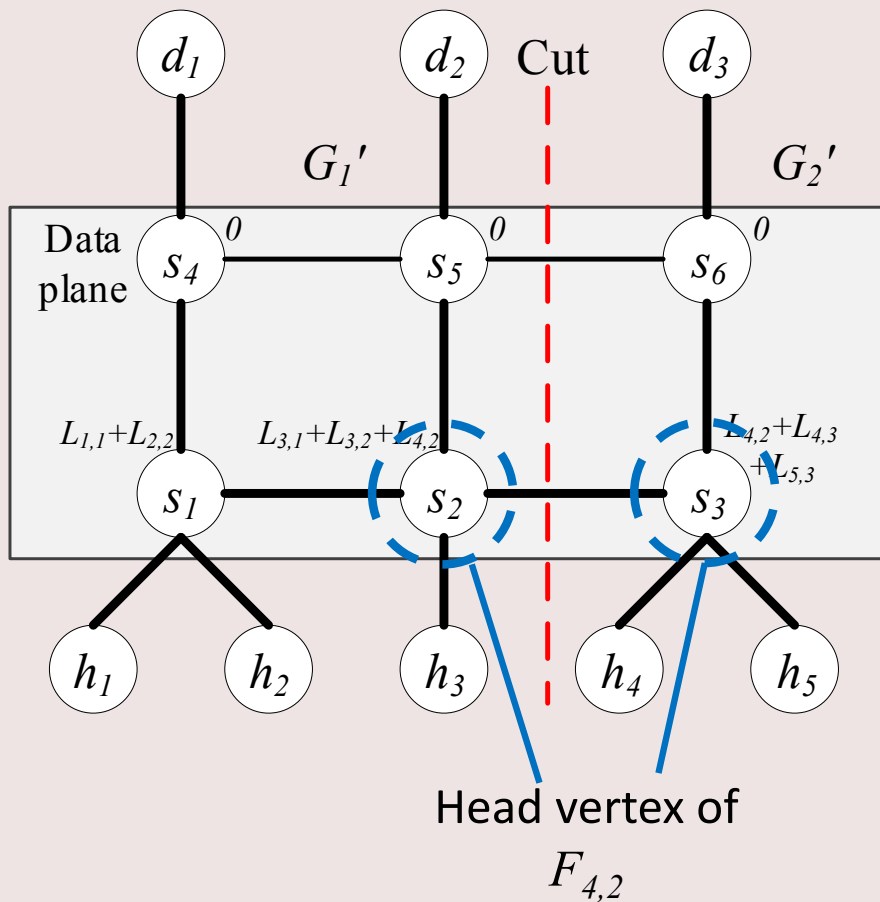

- The cost of cut:

$$\text{cost}(\text{cut}) = \sum_{e_{uv} \in \text{cut}} L(e_{uv}) + \sum_{u \in V_1} \Delta n(u, c_1) + \sum_{v \in V_2} \Delta n(v, c_2)$$

- The total load of switch s to controller c :

$$L(s, c) = \sum_{F_{i,j} \in \mathbf{F}} L(F_{i,j}) \mathbf{1}(s = F_{i,j}^{(1)})$$

- The load of a subgraph G'_i :

$$L(G'_i) = \sum_{s \in G'_i} L(s, c_i)$$

Discussion

- A 2-way graph partitioning problem can be formulated as a minimum cut optimization problem as follows:

$$\begin{array}{ll} \min_{CUT} & \sum_{cut \in CUT} cost(cut) \\ \text{s.t.} & |L(G'_1) - L(G'_2)| \leq \varepsilon, \\ & L(G'_1), L(G'_2) \leq L_{max}, \\ & T(G'_1), T(G'_2) \leq T_{max}. \end{array}$$

- The k -way partitioning problem is most frequently solved by recursive bisection.
- PASIN not only partitions the data plain into multiple domains with minimum cost, but also provides a reasonable map between the gateways and the controllers, i.e., $M : h \rightarrow c$.
- PASIN partitions the network according to the distribution of data traffic to reduce the total load of requests with a constraint of load balance among domains. (Compared with UbiFlow)

Introduction to SD-IoT Network

Partitioning Problem of Large-scale SD-IoT

Solution: PASIN

Evaluation Results

Conclusion

Offloading Data at APs

- The Taxi-ROMA dataset contains real mobility traces of taxi cabs in Rome, Italy. It contains GPS coordinates of approximately 320 taxis collected over 30 days.

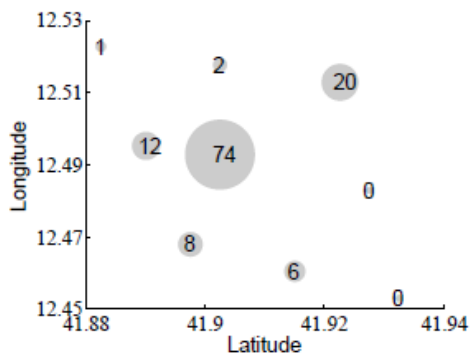

(a) Northeast event

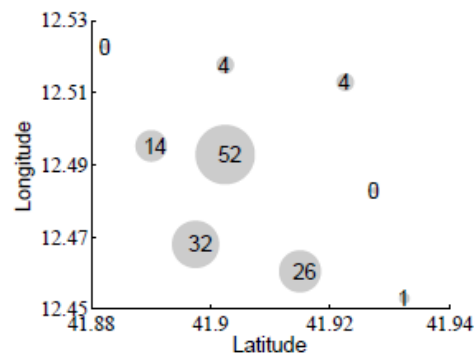

(b) Southeast event

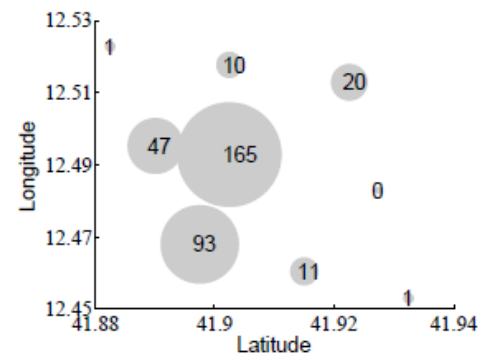

(c) Southwest event

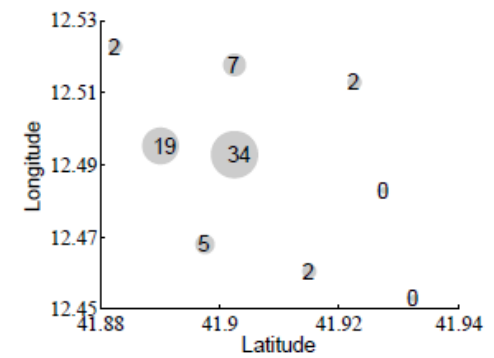

(d) Northwest event

- These results imply the relationship between the sensing events and the uploading APs, which relate to the traffic patterns.

Limitation of Controllers

- To verify the limitation of the capability of the controller, we evaluate the performance of SDN with linear topology.
- The data plane contains 6 switches and the control plane contains 2 controllers. Each of the two hosts ($load_1$ and $load_2$) connected to the switches s_2 and s_5 generates a load of 50 UDP packets with unreachable destinations per second, and these packets are flooded to the whole network. The size of each UDP packet is 67 Bytes.

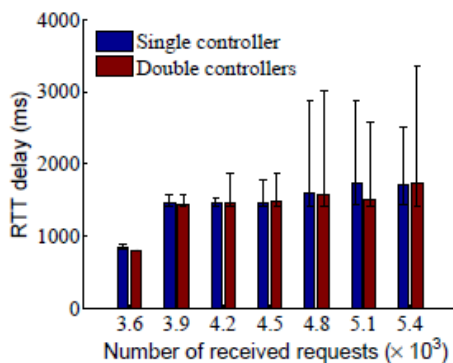

(a) RTT delay

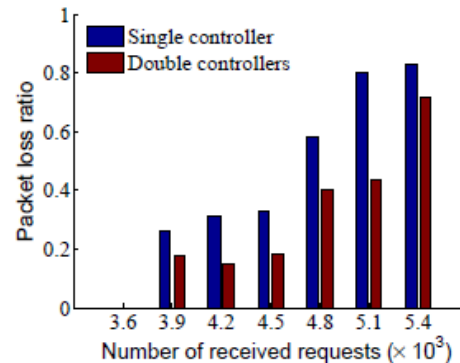

(b) Loss ratio

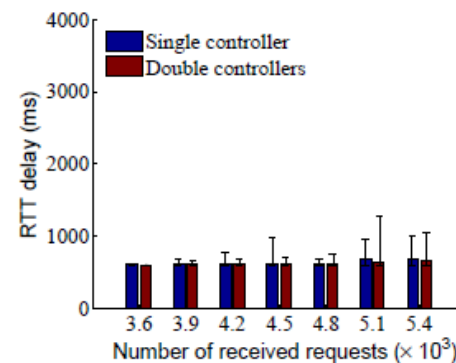

(a) RTT delay

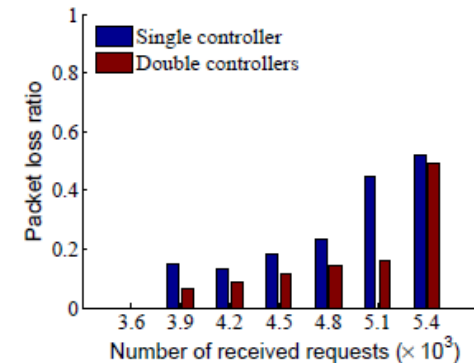

(b) Loss ratio

Inter-domain data transmission ($h_1 \rightarrow h_6$).

Intra-domain data transmission ($h_1 \rightarrow h_2$).

Partitioning

- To verify the performance of PASIN, we compare it with two other approaches:
 - Single: the whole network contains only one controller and one domain for all the switches;
 - UbiFlow: multiple controllers are deployed to divide the network into several partitions, which represent different geographical areas.

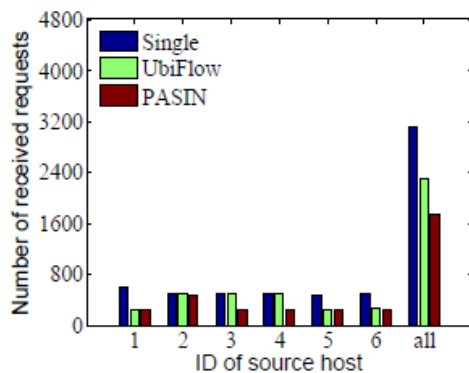

(a) Mean of each controller

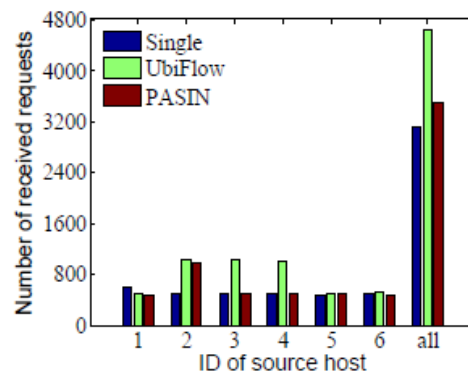

(b) Total of whole control plane

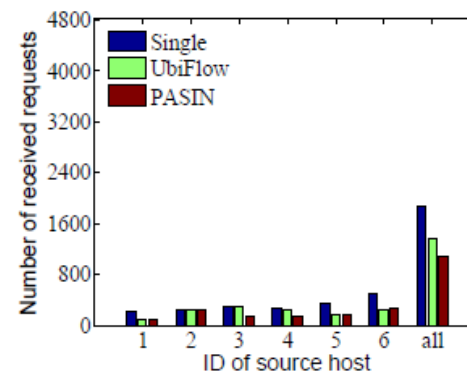

(a) Mean of each controller

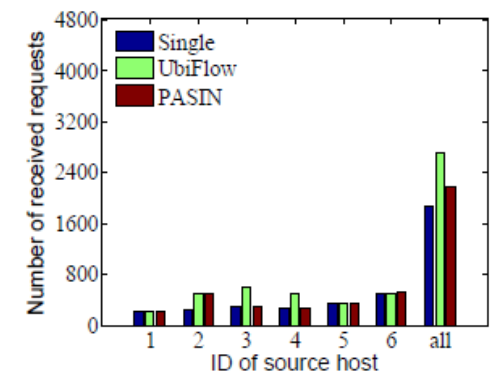

(b) Total of whole control plane

Average number of received requests under uniform data rate.

Average number of received requests under non-uniform data rate.

Conclusion

- We investigate the partitioning problem over multiple flow paths in SDN, with the urban sensing applications for detecting spatial events.
- We analyze the non-uniform distribution of sensing data from the events to the data server using a hypergraph.
- We propose a Partitioning Algorithm for Software-defined IoT Network (PASIN) to achieve our objective of minimum total load of requests, with the constraint of total switch-to-controller delays in each domain.



Thank You!
Q&A



电子科技大学
University of Electronic Science and Technology of China

